

5-SERIES

- TW 57-5** - 5.7m (18'10") reach
- TW 60-5** - 6.0m (19'8") reach
- TW 67T-5** - 6.7m (22'2") reach
- TW 77T-5** - 7.7m (25'3") reach



Parallel Arm Geometry

Hydraulic Slew

Twose's 5-Series machines come with a productive specification and a suite of advanced features that make them an ideal tool for professional contractors.

3pt linkage mounting with heavy duty stabiliser

EXTRA FOR THIS SERIES
High capacity 200ltr oil reservoir

EXTRA FOR THIS SERIES
65hp hydraulic system

EXTRA FOR THIS SERIES
Axle mounting option

EXTRA FOR THIS SERIES
Hydraulic oil cooler with auto reversing fan

TWOSE 5-SERIES REACH ARM



PURPOSE-BUILT, FOR PROFESSIONALS

Twose's flagship 5-Series offers four different reach options from 5.7 to 7.7m, 65hp high-performance hydraulics, and a choice of proportional control systems.

Three different armsets are available including: Standard; Telescopic – for added extra reach on demand; and Variable Forward Reach (VFR) – enhancing comfort, visibility and reducing fatigue.



Oil cooler fitted as standard. See page 20 for details

5-SERIES REACH ARM				
Specification	TW 57-5 HI	TW 60-5	TW 67T-5	TW 77T-5
HP	65hp	65hp	65hp	65hp
Reach	5.7m	6.0m	6.7m	7.7m
Slew	■	■	■	■
Angle Float	■	■	■	■
Lift Float	□	□	□	□
Mounting	3pt	3pt	3pt	3pt or Axle
Oil Cooler	■	■	■	■
Road Lighting	□	□	□	□
Weight	1470kg	1482kg	1611kg	TBC
Oil Tank	200ltr	200ltr	200ltr	200ltr
Safety Breakaway	Hydraulic	Hydraulic	Hydraulic	Hydraulic
Axle Mounting	□	□	□	■
ARM SETS				
Standard	—	—	—	—
Parallel Arm Geometry	■	■	■	■
Telescopic	—	—	■	■
VFR	—	□	—	—
CONTROLS				
Proportional Cable	□	□	—	—
Proportional Low Pressure	□	□	□	—
Proportional Electric Controls	□	□	□	□
FLAILHEADS				
1.0m Compact Flailhead	—	—	—	—
1.2m Compact Flailhead	—	—	—	—
1.2m Sliding Mount, Direct Drive Flailhead	■	■	■	■
1.5m Sliding Mount, Direct Drive Flailhead	□	□	□	□
REQUIREMENTS				
Minimum tractor weight	3000kg	3000kg	3750kg	5500kg
Minimum tractor horsepower	70hp	70hp	100hp	120hp

■ Standard Equipment □ Optional Equipment — Not available

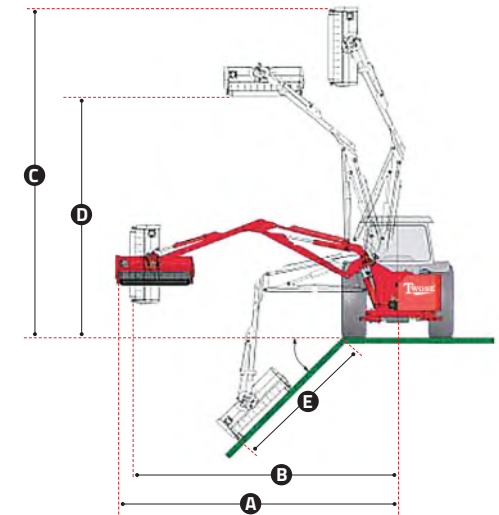

Note - Visual for illustration only

REACH DIMENSIONS

MODEL	A	B	C	D	E
TW 57-5 HI	5.7m	5.4m	6.6m	5.2m	3.7m
TW 60-5	6.0m	5.7m	6.9m	5.2m	3.8m
TW 67T-5	6.7m	6.2m	7.2m	5.5m	4.2m
TW 77T-5	7.7m	7.2m	7.1m	8.5m	3.9m

* Dimensions based on 1.2m Sliding Mount Flailhead

SPECIFICATION

- 5.7m, 6.0m, 6.7m & 7.7m reach
- 3-point linkage
- 65hp hydraulics

ARMSETS

- Standard (5.7m & 6.0m)
- Parallel arm geometry (all models)
- Telescopic (6.7m & 7.7m)
- Variable Forward Reach (VFR) (6.0m)

CONTROLS

- Proportional cable controls
- Proportional low pressure hydraulic controls
- Proportional electric controls

KEY FEATURES

- 240-degree head rotation
- Dual direction cutting
- Hydraulic slew
- Hydraulic breakaway protection
- 200-litre oil tank capacity
- Cast iron pumps and motor
- Angle float
- Road lighting (optional)
- Lift float (optional)
- Axle mounting (optional)
- Oil cooler kit

FLAILHEADS

- 1.2m sliding mount direct drive flailhead
- 1.5m sliding mount direct drive flailhead

ATTACHMENTS

- Sawheads
- Cutterbars

TRACTOR REQUIREMENTS

- From 70hp, 3,000kg