

4-SERIES

TW 55-4 - 5.5m (18') reach



Parallel Arm Geometry

Purpose-built for farmers and contractors, the 4-Series offers productivity and precision at an affordable price.

EXTRA FOR THIS SERIES
Hydraulic Slew

3pt linkage mounting with heavy duty stabiliser

Large 140ltr oil capacity

50hp hydraulic system

EXTRA FOR THIS SERIES
Sliding mount flailhead

TWOSE 4-SERIES REACH ARM



PRODUCTIVE AND FEATURE- PACKED

Twose's most advanced mid-range machine, the TW 55-4 features the proven low pressure hydraulic proportional joystick; competitive 5.5m reach; 50hp hydraulics; and a 90-degree hydraulic slew with breakaway protection.

Compatible with tractors of just 60hp and upwards, the machine is equipped with a double-skin heavy duty 1.2m flailhead and is available with more than 10 different cutting attachments, including Sawheads and Cutterbars.



The 4-Series incorporates Hydraulic Slew. See page 21 for details.

4-SERIES REACH ARM	
Specification	TW 55-4
HP	50hp
Reach	5.5m
Slew	■
Angle Float	■
Lift Float	□
Mounting	3pt
Oil Cooler	□
Road Lighting	□
Weight	1340kg
Oil Tank	140ltr
Safety Breakaway	Hydraulic
ARM SETS	
Standard	—
Parallel Arm Geometry	■
Telescopic	—
VFR	—
CONTROLS	
Proportional Cable	■
Proportional Low Pressure	□
Proportional Electric Controls	□
FLAILHEADS	
1.0m Compact Flailhead	—
1.2m Compact Flailhead	—
1.2m Sliding Mount, Direct Drive Flailhead	■
1.5m Sliding Mount, Direct Drive Flailhead	—
REQUIREMENTS	
Minimum tractor weight	2500kg
Minimum tractor horsepower	60hp

■ Standard Equipment □ Optional Equipment — Not available

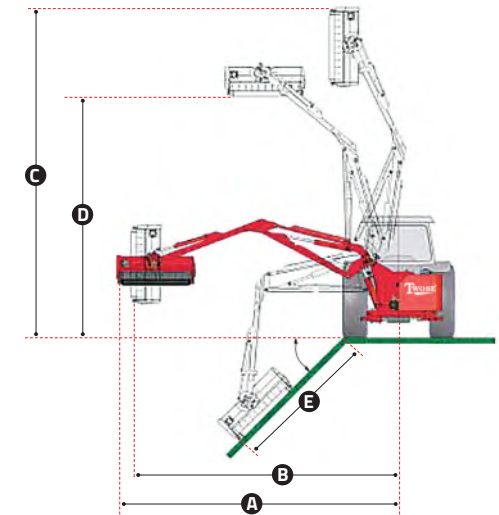

Note - Visual for illustration only

REACH DIMENSIONS

MODEL	A	B	C	D	E
TW 55-4	5.5m	5.0m	6.2m	4.8m	3.1m

* Dimensions based on 1.2m Sliding Mount Flailhead

SPECIFICATION

- 5.5m reach
- 3-point linkage
- 50hp hydraulics

ARMSETS

- Standard straight arm
- Parallel arm geometry

CONTROLS

- Proportional cable controls
- Proportional low pressure hydraulic controls
- Proportional electric controls

KEY FEATURES

- 240-degree head rotation
- Dual direction cutting
- Hydraulic slew
- Hydraulic breakaway protection
- 140-litre oil tank capacity
- Cast iron pumps and motor
- Angle float
- Road lighting (optional)
- Lift float (optional)

FLAILHEADS

- 1.2m sliding mount direct drive flailhead

ATTACHMENTS

- Sawheads
- Cutterbars

TRACTOR REQUIREMENTS

- 60hp, 2,500kg