

1-SERIES

TW 32-1 - 3.2m (10'6") reach

TW 42-1 - 4.2m (13'9") reach

Hydraulic auto-reset

KEY FEATURE FOR THIS SERIES

Compact flailhead with sliding mount

KEY FEATURE FOR THIS SERIES

Parallel Arm Geometry

Created for the amenities, ground-care and landscaping sectors, Twose's 1-Series machines thrive in parks, public spaces and confined environments.

KEY FEATURE FOR THIS SERIES

Proportional Cable controls

80ltr oil capacity

30hp hydraulic system



TWOSE

1-SERIES REACH ARM



COMPACT AND MANOEUVRABLE

Twose's specialist compact series features a choice of 3.2m and 4.2m models with 30hp hydraulics and advanced parallel arm geometry for outstanding manoeuvrability and precision.

Highly adaptable, 1-Series machines can be fitted quickly and easily on a wide range of utility vehicles. Their low horsepower requirements mean they are compatible with tractors of just 35hp (TW 32-1) or 50hp (TW 42-1).



The Twose Sliding Mount Direct Drive Flailhead.

1-SERIES REACH ARM		
Specification	TW 32-1	TW 42-1
HP	30hp	30hp
Reach	3.2m	4.2m
Slew	—	—
Angle Float	■	■
Lift Float	□	□
Mounting	3pt	3pt
Oil Cooler	—	—
Road Lighting	□	□
Weight	400kg	523kg
Oil Tank	80ltr	80ltr
Safety Breakaway	Hydraulic	Hydraulic
ARM SETS		
Standard	—	—
Parallel Arm Geometry	■	■
Telescopic	—	—
VFR	—	—
CONTROLS		
Proportional Cable	■	■
Proportional Low Pressure	—	—
FLAILHEADS		
1.0m Compact Flailhead	■	■
1.2m Compact Flailhead	—	—
1.2m Sliding Mount, Direct Drive Flailhead	—	—
1.5m Sliding Mount, Direct Drive Flailhead	—	—
REQUIREMENTS		
Minimum tractor weight	1300kg	2000kg
Minimum tractor horsepower	35hp	50hp

■ Standard Equipment □ Optional Equipment — Not available

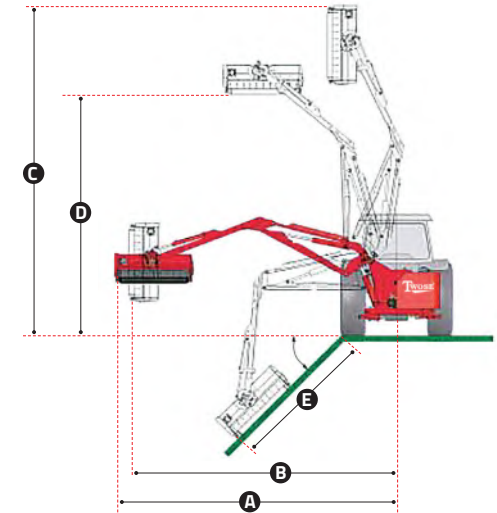

Note - Visual for illustration only

REACH DIMENSIONS

MODEL	A	B	C	D	E
TW 32-1	3.2m	3.0m	4.1m	3.2m	1.8m
TW 42-1	4.2m	4.1m	4.9m	4.0m	2.9m

* Dimensions based on 1.0m Sliding Mount Flailhead

SPECIFICATION

- 3.2m & 4.2m reach
- 3-point linkage (CAT I and CAT II)
- 30hp hydraulics

ARMSETS

- Standard straight arm
- Parallel arm geometry

CONTROLS

- Proportional cable controls

KEY FEATURES

- Dual direction cutting
- Hydraulic breakaway protection
- 80-litre oil tank capacity
- Aluminium pumps and motor
- Angle float
- Road lighting (optional)
- Lift float (optional)

FLAILHEADS

- 1.0m compact flailhead

ATTACHMENTS

- Sawheads
- Cutterbars

TRACTOR REQUIREMENTS

- TW 32-1 - 35hp, 1,300kg
- TW 42-1 - 50hp, 2,000kg